

UF250BMB-H1 series

-H1C2A

(standard with Frame)

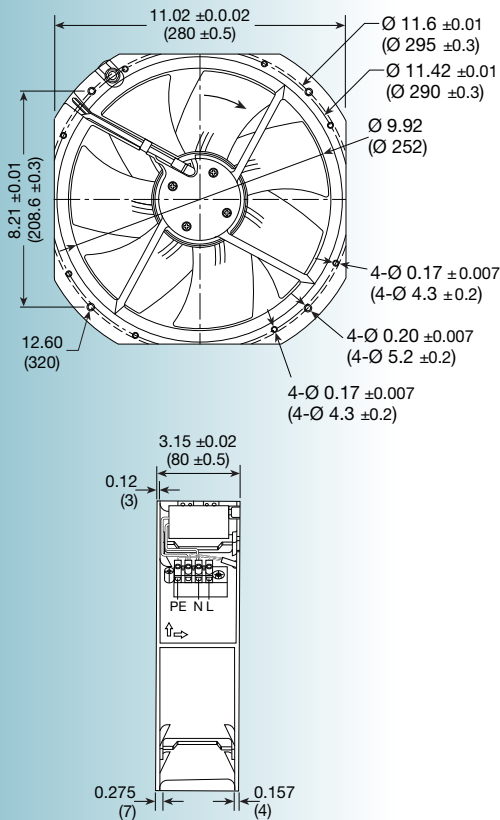

Size: (280 x 280 x 80 mm)
11.0 x 11.0 x 3.15 inches

Features: *metal frame and impeller; Class F insulation; -20° ~ 70°C operating temperature range; high-temp bearing lubricant*

Operating voltage (VAC): 115 or 230
Bearing option: motor quality ball bearings
Motor: permanent split capacitor
Air flow: exhaust over struts
Connection: terminal/lead wires
Protection: thermal

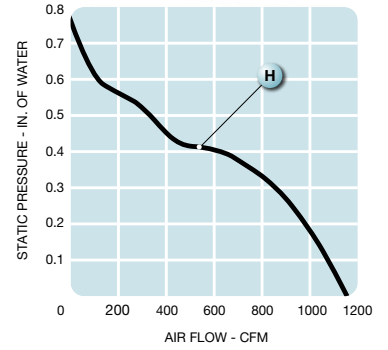

Model No.	Rated Voltage V	Freq. HZ	Input Power W	Rated Cur. A	Locked Cur. A	Speed RPM	Air Volume		Max. Static Pressure (H ₂ O)		Sound Noise db
							M ³ /Min.	CFM	MM	INCH	
UF250BMB12-H1	115	60	148	1.50	1.90	2700	32	1130	20	0.78	70
UF250BMB23-H1	230	60	158	0.82	0.91	2700	32	1130	20	0.78	70

-H1C2B

(With Guard/No Frame)

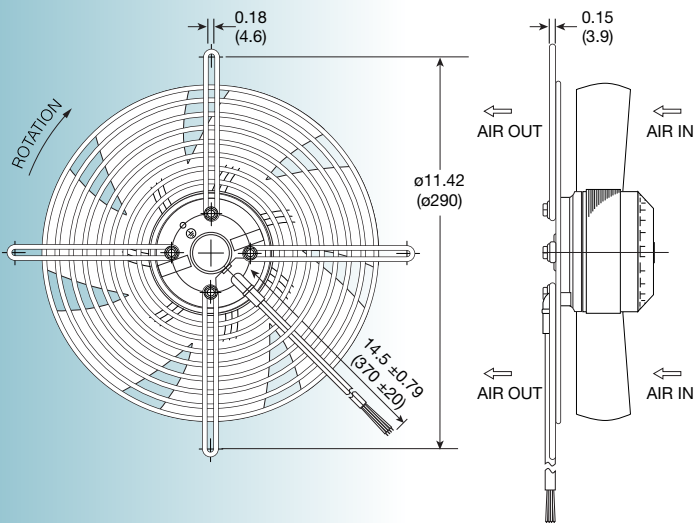

-H1C2C

(Without Frame or Guard)

