

HIGH PERFORMANCE

G9225-G series

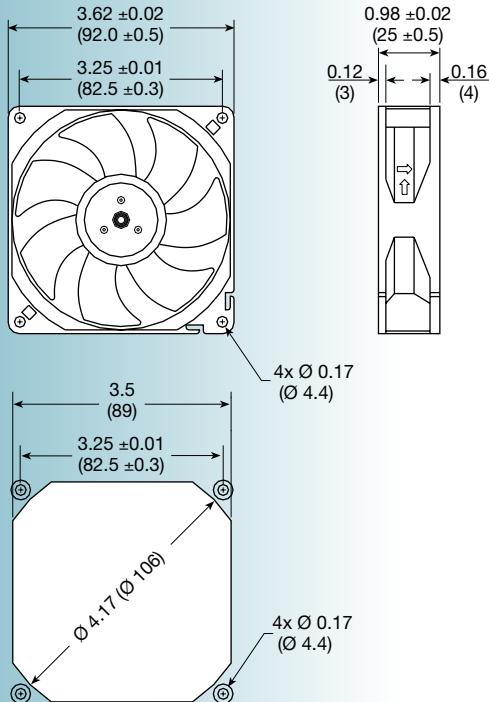

Size: (92 x 92 x 25 mm)
3.62 x 3.62 x 0.98 inches

- Features:** *high performance*
Construction: UL94V-0 PBT impeller & frame
Bearing option: ball bearing or sleeve
Connection: AWG 24, UL1007 lead wires
Frame: flanged or ribbed
Protection: thermal
Options: tachometer output;
 locked rotor alarm signal;
 encapsulated motor

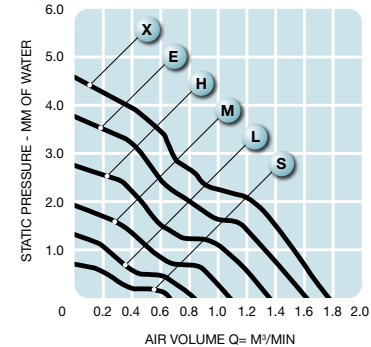

Model No.	Rated Voltage V	Current mA			Revolution RPM	Air Volume		Max. Static Pressure (H ₂ O)		Sound Noise dbA	Weight g
		5	12	24		M ³ /Min.	CFM	MM	INCH		
G9225S-G	5/12/24	220	90	60	1,200	0.68	24	0.71	0.03	19	98
G9225L-G	5/12/24	340	140	90	1,600	0.88	31	1.33	0.05	21	98
G9225M-G	5/12/24	480	200	120	2,000	1.13	40	1.94	0.07	23	98
G9225H-G	12/24	-	280	160	2,400	1.36	48	2.75	0.10	26	98
G9225E-G	12/24	-	370	200	2,800	1.55	55	3.78	0.13	30	98
G9225X-G	12/24	-	490	290	3,200	1.84	65	4.60	0.17	34	98