

# DC

## THIN PROFILE M5010 series

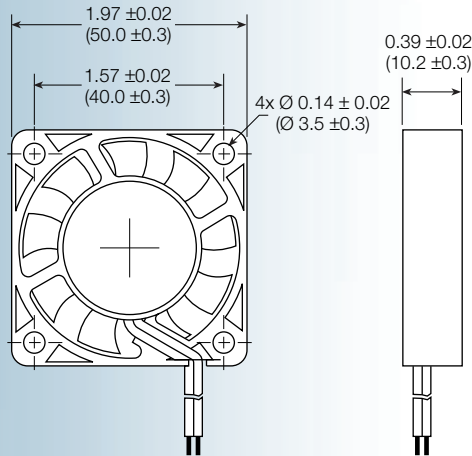

**Size: (50 x 50 x 10 mm)**  
**1.97 x 1.97 x 0.39 inches**

**Construction:** UL94V-0 PBT impeller & frame

**Bearing option:** ball bearing or sleeve

**Connection:** AWG 26, UL1007 lead wires

**Frame:** ribbed

**Protection:** impedance

**Options:** tachometer output signal

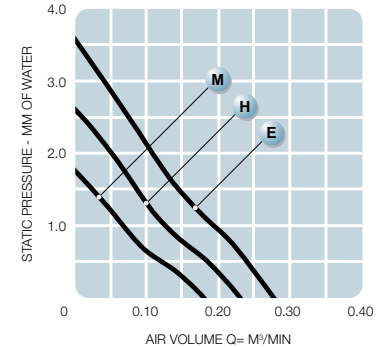

Model No.	Rated Voltage V	Operating Voltage V	Current mA	Revolution RPM	Air Volume		Max Static Pressure (H <sub>2</sub> O)		Sound Noise dBA	Weight g
					M <sup>3</sup> /Min	CFM	MM	INCH		
M5010M	5	3-6.0	60	4,000	0.18	6.36	1.77	0.07	24	20
M5010H	5	3-6.0	80	5,000	0.23	8.12	2.63	0.11	26	20
M5010E	5	3-6.0	150	6,000	0.28	9.89	3.60	0.14	28	20
M5010M	12	7 - 13.8	70	4,000	0.18	6.36	1.77	0.07	24	20
M5010H	12	7 - 13.8	90	5,000	0.23	8.12	2.63	0.11	26	20
M5010E	12	7 - 13.8	110	6,000	0.28	9.89	3.60	0.14	28	20